



# Collins Manufacturing Corp

## HI-SPEED® DOLLY INSTRUCTIONS AND PRECAUTIONS

Questions? Phone: (800) 332-9220 Email: collinsdollies@aol.com

### RAISING ALL COLLINS HI-SPEED® DOLLIES: 1975 - PRESENT

1. **ADJUST TELESCOPIC CROSS RAILS** BY FIRST DEPRESSING SPRING-LOADED PLUNGER AND SLIDING OUTER TUBE UNTIL PLUNGER LOCKS INTO HOLE THAT MATCHES TOWED VEHICLE WIDTH.

2. **PLACE CROSS RAILS (A)** FORE AND AFT OF VEHICLE'S TIRES. TIRES SHOULD BE AS CLOSE TO END OF CROSS RAILS AS POSSIBLE.



3. **PLACE DOLLY IN COLLAPSED POSITION** BESIDE VEHICLE TIRE TO BE LIFTED, WITH DOLLY TIRES ABOVE DOLLY BODY (J).



4. **DISENGAGE SAFETY LOCK (C)** ALLOWING SPINDLE ASSEMBLY AND TRIP ASSEMBLY FREE MOTION. ROTATE SPINDLE TO END OF DOLLY BODY (J).

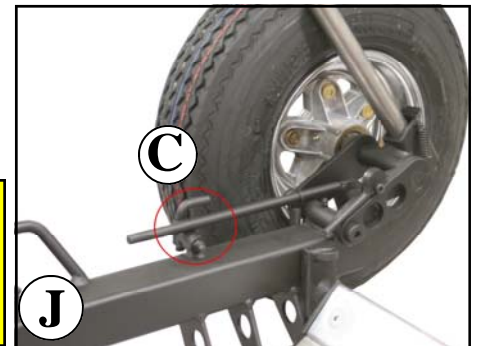

#### **SAFETY WARNING!**

**FAILURE TO DISENGAGE SAFETY LOCK BEFORE RAISING DOLLY WILL CAUSE TRIP HANDLE TO BEND, POTENTIALLY ALLOWING TRIP ASSEMBLY TO PREMATURELY RELEASE. (SEE "TROUBLE SHOOTING," PAGE 5)**

5. **SET RAIL END (B)** INTO ONE OF THREE RAIL POCKET (I) SLOTS, ADJUSTING FOR DIAMETER OF VEHICLE'S TIRES, POSITIONING CROSS RAIL AS CLOSE AS POSSIBLE TO VEHICLE TIRE TREAD.

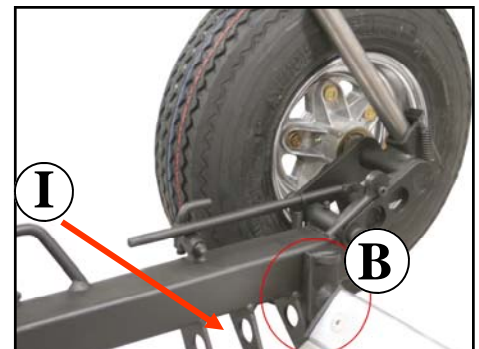

6. **ENGAGE SAFETY RATCHET (D)** BY ROTATING RATCHET CAM HANDLE TOWARD DOLLY FRAME.

#### **SAFETY WARNING!**

**RAISING ANY DOLLY WITHOUT A SAFETY RATCHET SYSTEM CAN BE HAZARDOUS, AS IT MAY LEAD TO PERSONAL INJURY, VEHICLE OR PROPERTY DAMAGE, AND POTENTIAL LAW SUITS. PAY CLOSE ATTENTION TO THIS MOST CRUCIAL SAFETY WARNING!**



## RAISING THE COLLINS HI-SPEED® DOLLY (CONTINUED)

7. INSERT PRY BAR (E) INTO PRY POCKET (F).

### **SAFETY PRECAUTIONS:**

**PRIOR TO LIFTING VEHICLE MAKE SURE IMMEDIATE AREA IS CLEARED OF OTHER PERSONNEL**

**ENSURE SECURE FOOTING TO AVOID SLIPPING AND FALLING.**

**FIRMLY GRIP PRY BAR WITH BOTH HANDS.**

8. GRIPPING END OF PRY BAR (E), SWING IT IN AN ARC, FORCING SPINDLE ASSEMBLY FROM ABOVE DOLLY FRAME (J) TO BELOW DOLLY FRAME, THEREBY LIFTING VEHICLE WHEEL (T) OFF THE GROUND. IF NEEDED, BETTER LEVERAGE MAY BE OBTAINED WHILE LIFTING VEHICLE WITH SAFETY RATCHETS ENGAGED. ALLOW VEHICLE WEIGHT TO REST ON RATCHET GEAR WHILE REPOSITIONING FEET, TO GET A BETTER PURCHASE OF PRY BAR FOR LEVERAGE.

9. WATCH AND LISTEN FOR RELEASE HANDLE (G) TO RISE THEN SNAP BACK INTO PLACE, AS TRIP ASSEMBLY LOCKS DOWN SPINDLE ASSEMBLY (H) IN THE LOADED POSITION. DOLLY IS NOW LOCKED AND LOADED — PRY BAR CAN NOW BE REMOVED.

10. ENGAGE SAFETY LOCK (C) OVER RELEASE HANDLE (G). LEAVE SAFETY RATCHET (D) ENGAGED AS A FAIL-SAFE BACKUP, TO PREVENT DOLLY FROM DROPPING WHILE VEHICLE IS IN TOW.

11. REPEAT THIS ACTION FOR ALL FOUR ASSEMBLIES. DOLLY IS NOW SECURE.

12. SAFETY TIE-DOWN STRAPS (M) SHOULD ALWAYS BE USED TO SECURE DOLLY TO VEHICLE.

### **SAFETY WARNING!**

**ENSURE THAT SAFETY RATCHETS AND SAFETY LOCKS ARE ENGAGED TO PREVENT PREMATURE RELEASE OF DOLLY WHILE IN TOW, CAUSING VEHICLE ACCIDENTS.**

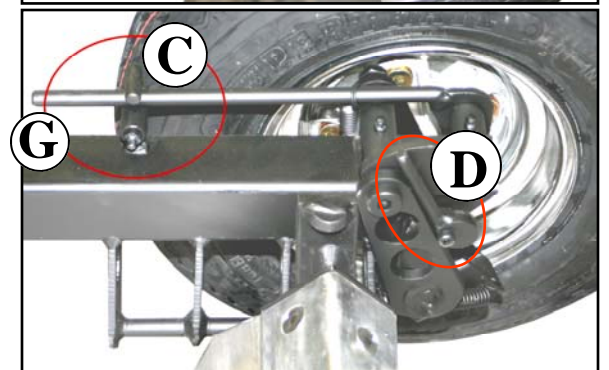
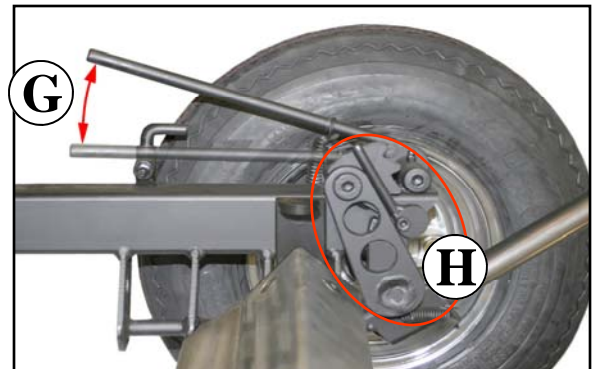
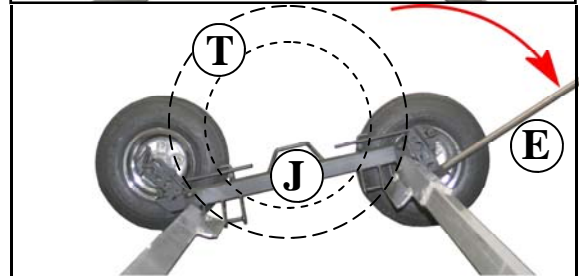
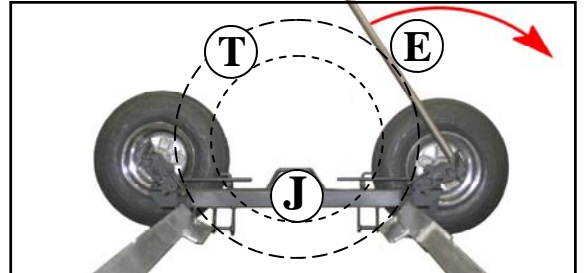
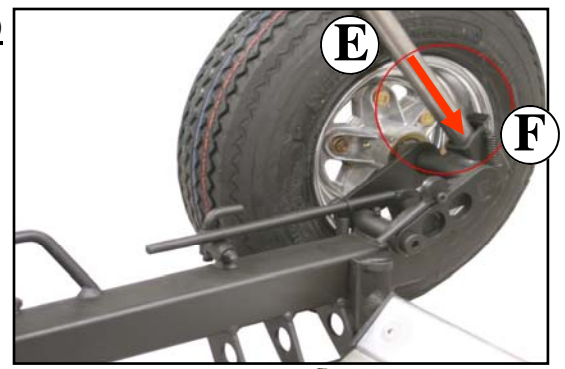

## QUICK LOWERING OF ALL COLLINS HI-SPEED® DOLLIES: 1975 - PRESENT

1. REMOVE SAFETY TIE-DOWN STRAPS (M) FROM DOLLY AND VEHICLE TIRE.

2. DISENGAGE SAFETY RATCHETS (D) BY ROTATING RATCHET CAM HANDLE DOWN.

3. DISENGAGE SAFETY LOCKS (C) BY TURNING THEM TOWARD END OF DOLLY BODY (J).

4. WHILE FACING DOLLY, PLACE BOTH HANDS BELOW EACH END OF TRIP HANDLES.

### **CAUTION:**

**KEEP TOES CLEAR OF THE DOLLY. TIRES ACTUALLY ROLL AWAY FROM OPERATOR.**

**ENSURE THERE ARE NO OVERHANGING OBJECTS, LIKE IN BACK OF A PICKUP TRUCK, THAT MIGHT STRIKE PERSONNEL WHILE LOWERING VEHICLE.**

5. GENTLY LIFT RELEASE HANDLES TOGETHER OR ONE AT A TIME. THIS ALLOWS DOLLY TO LOWER TO THE GROUND, A DISTANCE OF ABOUT SIX INCHES. STOW DOLLY ON TRUCK.

### **NOTE:**

**IF POSSIBLE, WHEN LOWERING DOLLY BY THE QUICK METHOD, CONCRETE SHOULD BE AVOIDED AS THE IMPACT COULD CHIP OR MAR THE SURFACE. HOWEVER, PLACING A RUBBER PAD BENEATH DOLLY BEFORE LOWERING, WOULD PROTECT CONCRETE.**

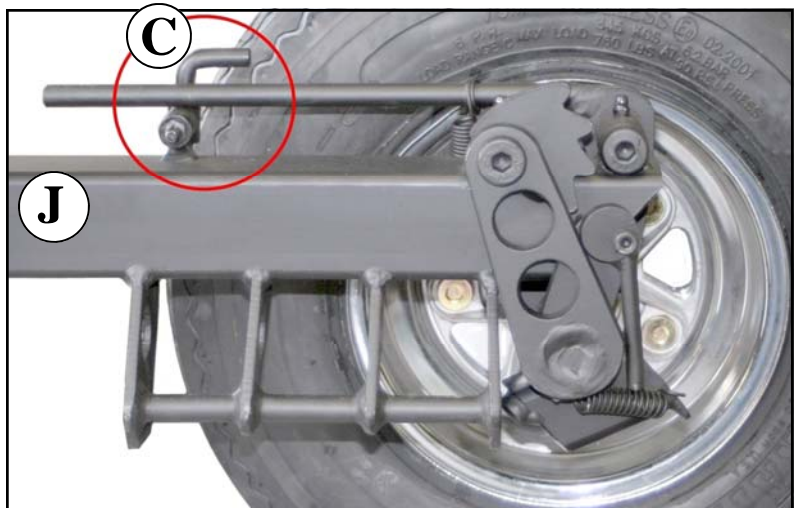
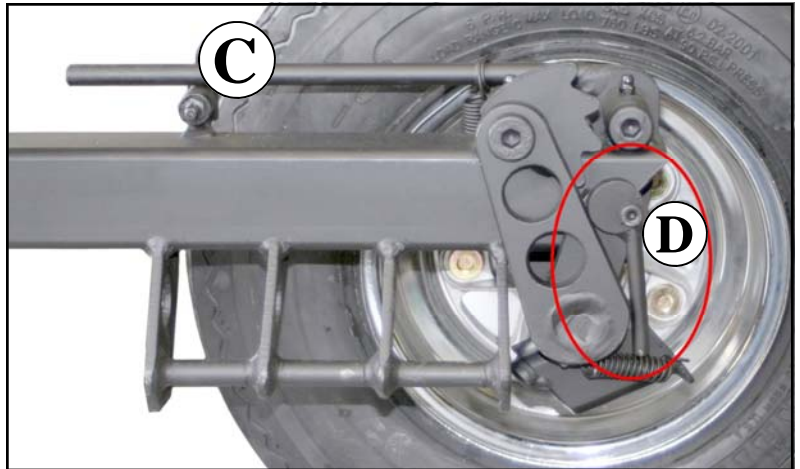

## GENTLE LOWERING OF THE COLLINS HI-SPEED® DOLLY: 1975 - PRESENT

1. **SKILL SET LEVEL: EXPERIENCED** — PRACTICE EMPTY MULTIPLE TIMES BEFORE ACTUAL LOADING!
2. DISENGAGE RATCHETS (D) AND SAFETY LOCKS (C) BY TURNING LOCKS TOWARD END OF DOLLY BODY (J).
3. ROLL SPINDLE ASSEMBLY (H) TO OUTSIDE AND INSERT PRY BAR (E) INTO PRY POCKET (F).
4. GRIP PRY BAR (E) WHILE AT THE SAME TIME PLACING OTHER HAND ON RELEASE HANDLE (G).
5. GENTLY LIFT TRIP HANDLE (G) WHILE SLOWLY ALLOWING SPINDLE ASSEMBLY (H) TO JUST CLEAR HEEL OF TRIP ASSEMBLY (L), A DISTANCE OF ABOUT ONE INCH.
6. WHEN SPINDLE ASSEMBLY (H) HAS JUST CLEARED TRIP ASSEMBLY (L), RELEASE TRIP HANDLE (G) AND FIRMLY PLACE BOTH HANDS ON END OF PRY BAR (E). AT THIS POINT PRY BAR WEIGHT IS ONLY 5-10 LBS.
7. WITH A FIRM GRIP, SLOWLY LET WEIGHT SHIFT TOWARD OPERATOR AS PRY BAR IS BROUGHT AROUND AND END OF DOLLY BODY (J) IS GENTLY LOWERED TO THE GROUND. REPEAT THIS FOR ALL FOUR ASSEMBLIES.

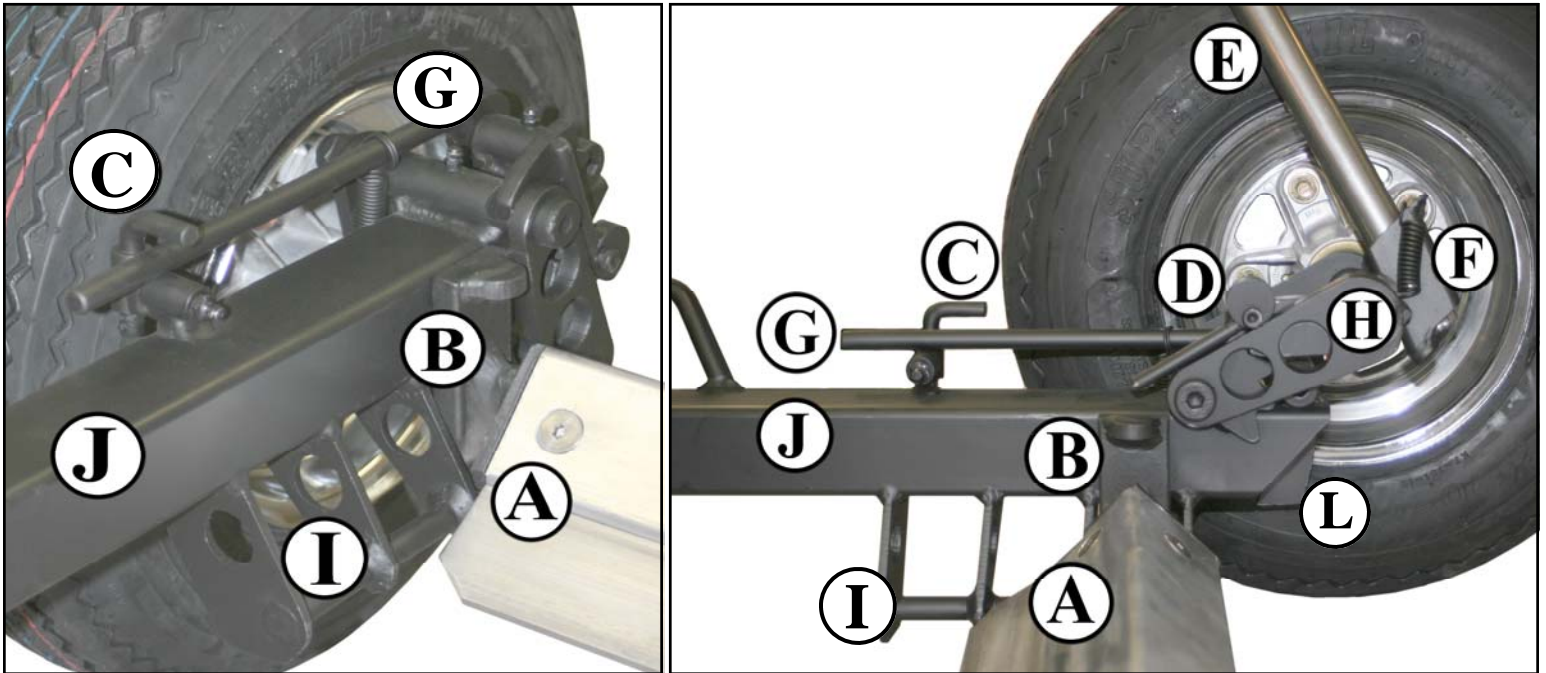

### MAINTENANCE AND CAUTIONS

1. FOR SAFEST OPERATION KEEP DOLLY MAINTAINED AND WELL LUBRICATED:
  - A. CHECK AND PACK BEARINGS AS NEEDED, KEEPING MOISTURE OUT.
  - B. LUBRICATE SAFETY RATCHET SYSTEM AS NEEDED — ESPECIALLY IN INCLEMENT WEATHER.
  - C. GREASE ALL DOLLY FITTINGS REGULARLY— HUB FITTINGS WITH **BEARING GREASE**
  - D. KEEP LUG NUTS TIGHTENED TO 75-85 FT-LBS.
  - E. CHECK TIRE CONDITION AND AIR PRESSURE BEFORE EACH OPERATION.
2. BEFORE RAISING ANY VEHICLES, COMPLETE OPERATION OF DOLLY SHOULD BE PRACTICED EMPTY.
3. WEAR WORK GLOVES AND ALWAYS KEEP A FIRM GRIP WHEN HANDLING PRY BAR.
4. MAKE SURE SAFETY LOCKS ARE **DISENGAGED BEFORE** RAISING DOLLY.
5. MAKE SURE SAFETY LOCKS ARE **ENGAGED AFTER** RAISING DOLLY.
6. AREA SHOULD BE CLEAR OF OTHER PERSONNEL WHILE OPERATING DOLLY.
7. DO NOT TOW FASTER THAN 50 MPH WITH 4.80 DOLLIES AND 60 MPH WITH 5.70 DOLLIES ON SMOOTH ROADS; SLOWER ON ROADS THAT ARE ROUGHER. POT HOLES SHOULD BE APPROACHED AT A CRAWL.
8. **DO NOT EXCEED TIRE MANUFACTURER'S RECOMMENDED LOAD CAPACITIES:**
  - 4.80 x 8 static load range: C = 760 lb. @ 90 psi per tire or 3,040 lb. per set of dollies w/ steel or aluminum axles.  
(4.80 x 8 static load range: C = 345 kg. @ 6.2 bar per tire or 1,379 kg. per set of dollies w/ steel or aluminum axles.)
  - 5.70 x 8 static load range: D = 1,070 lb. @ 100 psi per tire or 4,280 lb. per set of dollies w/ steel or aluminum axles.  
(5.70 x 8 static load range: D = 485 kg. @ 9.6 bar per tire or 1,941 kg. per set of dollies w/ steel or aluminum axles.)

# Trouble Shooting all Collins Hi-Speed<sup>®</sup> Dollies

FORCING SPINDLE DOWN WITH PRY BAR, WHILE SAFETY LOCK IS ENGAGED WILL BEND TRIP HANDLE, THEREBY CHANGING THE ANGLE OF THE TRIP BODY AS SHOWN BELOW IN RED, (BOTTOM RIGHT). TO STRAIGHTEN HANDLE, SIMPLY REMOVE TRIP SPRING AND SLIDE HOLLOW BAR OVER TRIP HANDLE. PRY UPWARDS UNTIL TRIP HANDLE IS STRAIGHT AND TOE POSITION OF FOOT IS TOP CENTER OF SPINDLE, AS SHOWN BELOW IN GREEN, (BOTTOM LEFT). REATTACH TRIP SPRING. DOLLY IS READY TO TOW.

